

VEICHI

Solution for Machine Tool Industry

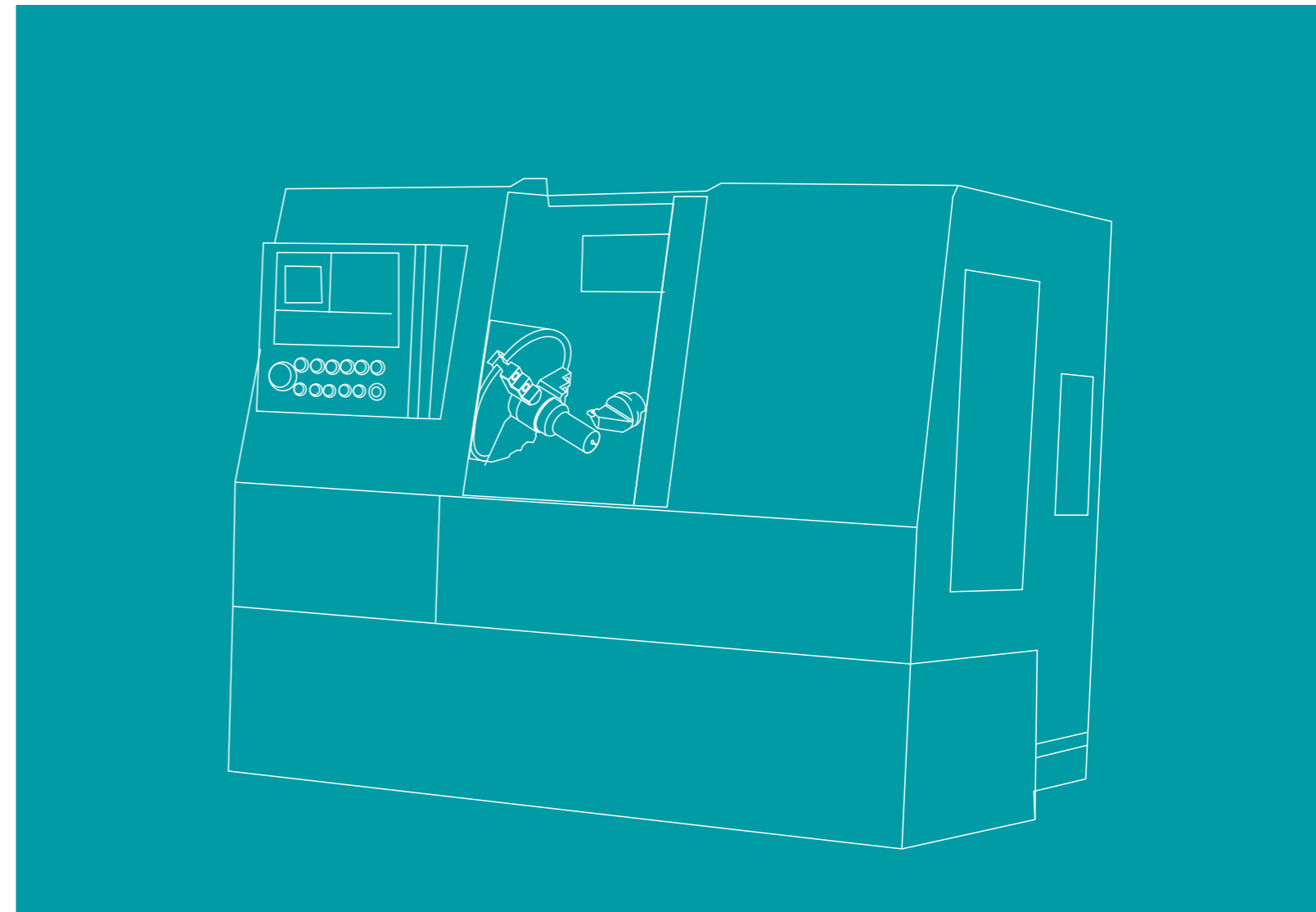

VEICHI

Shenzhen Veichi Electric Co., Ltd

Third floor, Building Chunsheng, Lulingya Industrial Park, No.1
Tangtou community, Shiyuan street, Baoan District, Shenzhen
Tel: +86-0755-3686 1688
Fax: +86-755-2968 5680 E-mail: overseas@veichi.com

Facebook: <https://www.facebook.com/veichiglobal/>

Suzhou Veichi Electric Co., Ltd

No.1000 Songjia road, Wuzhong Economic and Technological
Development Zone, Suzhou
Tel: +86-512-6617 1988
Fax: +86-512-6617 3610

Whatsapp: +86- 138 2881 8903

[Http://www.veichi.org](http://www.veichi.org)



Wechat Official Account

*Version 2019 V1.0
Veichi Electric Co., Ltd all rights reserved,
subject to change without notice.



SD500 spindle servo drive

Intelligent manufacture in China 2025

Professional product in machine tool industry



SD700 High performance servo system



Special drive AC300-Y for punch machine industry



Special drive AC300-C for spindle industry

High efficient, accuracy machining ,high automation, and high reliability have become the key index of the machine tool industry around the world.

Generally , CNC machine tools are inseparable from electronic control; For more than a decade, VEICHI deep plough machine tool industry is dedicated to creating the most professional machine tool industry products.

Independently developed motor control system for machine tool industry: SD700 series high-performance servo system and SD500 series spindle servo system perfectly fit " Intelligent manufacture in China 2025", cooperate with CNC manufacturers to provide a complete set of electronic control solutions for the machine tool industry, creating value for customers .

Multi solution on CNC machine tool industry

CNC milling machine, CNC lathe, machining center, CNC boring machine, gantry machine tool, CNC vertical lathe, CNC grinder, lathe and milling compound machine tool and other CNC equipment spindle drive



Tool magazine

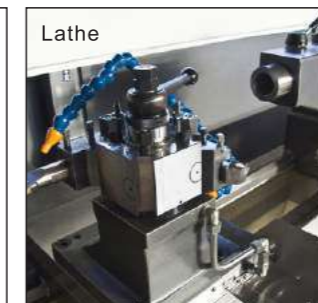

Lathe

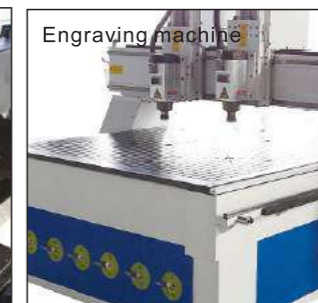

Engraving machine



Drilling and tapping Center

SD500 series spindle servo system

Integrated quality and the ingenious



SD500 spindle servo drive model explanation

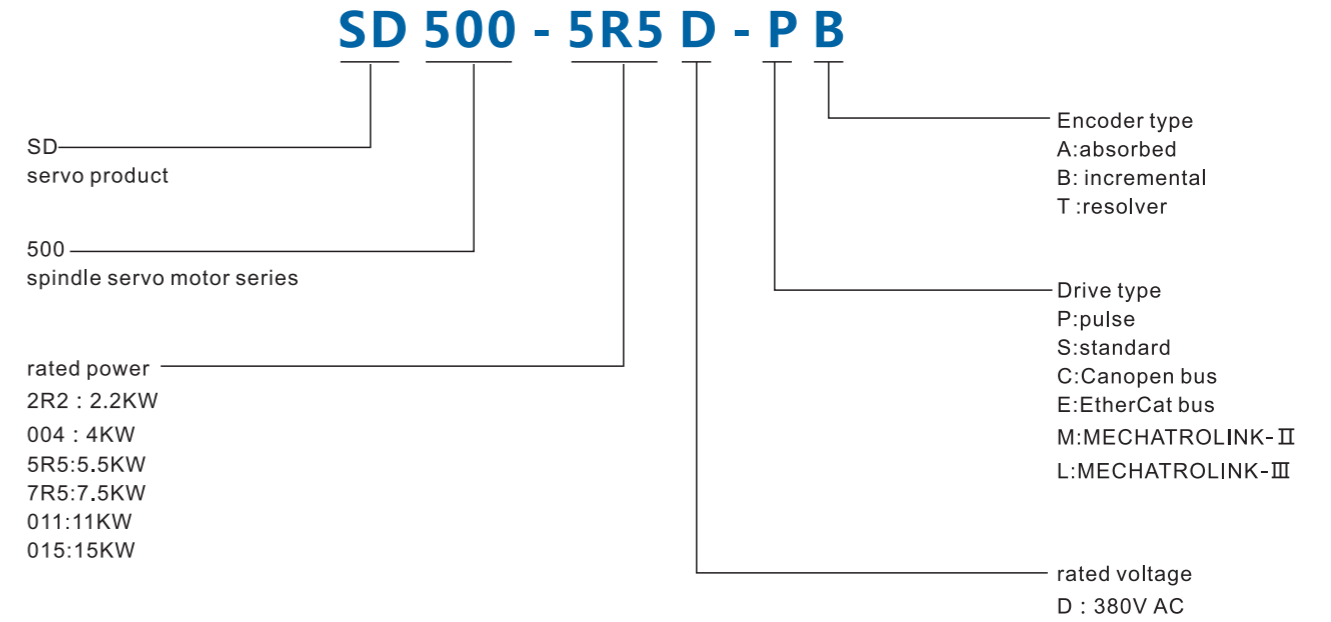

Installation dimensions

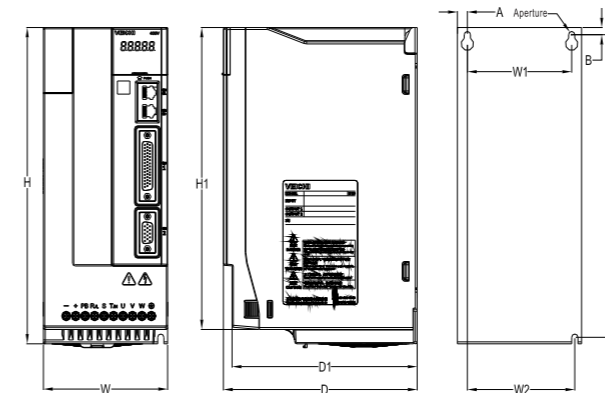

Model	Overall dimensions (mm)					Installation dimension(mm)					Installation aperture
	W	H	H1	D	D1	W1	W2	H2	A	B	
SD500-004D-*	100	242	231	156	149	84	86.5	231.5	8	5.5	3-M4
SD500-5R5D-*											
SD500-7R5D-*	116	320	307.5	176	169	98	100	307.5	9	6	3-M5
SD500-011D-*											

Model selection

Model	Input power	Rated AMP (A)	Motor(KW)	Brake unit	Adaptive resistor (Ω/KW)
SD500-004D-	Three phase 380V 50/60Hz	10	4	built-in	75/1.0
SD500-5R5D-		13	5.5		75/1.0
SD500-7R5D-		17	7.5		50/1.5
SD500-011D-		25	11		40/2



High precision in speed ,position mode ,positioning within ±1pulse



ARM+CPLD framework ,to meet higher performance requirements



Encoder cable break detection , guarantee the reliable system operation



Auto load inertia learning and loops parameters tuning



Full close loop vector control , dual encoder ports



Multi positioning points ,rigid tapping within ±2% precision



Design of book-type narrow-body structure to save installation space



Independent cooling duct and power components

Spindle servo motor model explanation

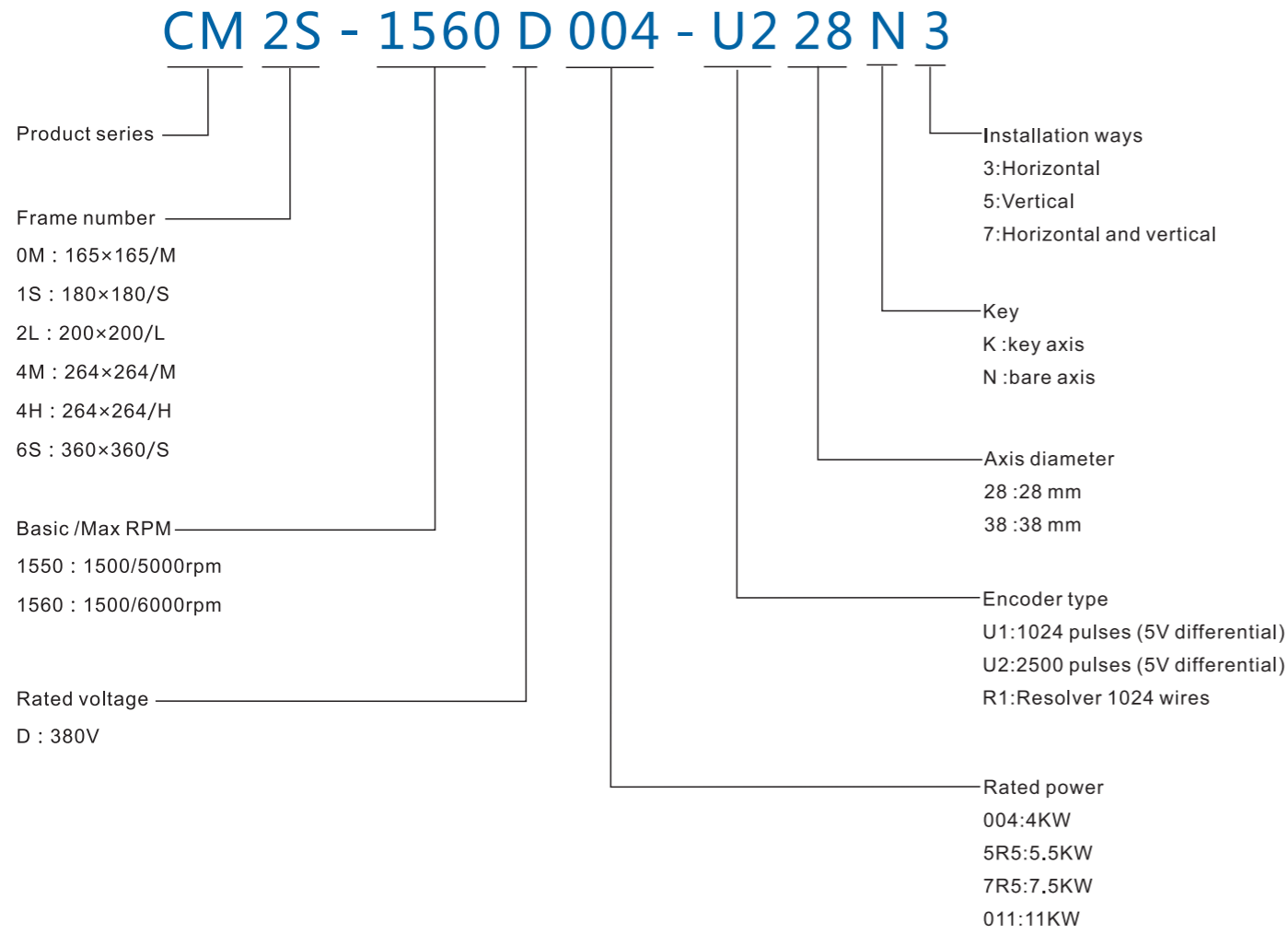

Spindle servo motor specification and installation dimensions

Model	Rated power(kW)		RPM(r/min)		VOLT(V)	AMP(A)		Torque (Nm)	Inertia kgm ²	Frame	L(mm)	L1(mm)	L2(mm)	N(mm)
	continuous	Basic /Max	Basic /Max	Rated		continuous	continuous							
CM1S-1560D1R5-	1.5	1500/6000	1500/6000	380	3.8	9.6	0.0058	0S	310	70	-	4		
CM1S-1560D2R2-	2.2	1500/6000	1500/6000	380	5.1	14	0.0077	0M	335	95	112	6		
CM1M-1560D004-	4	1500/6000	1500/6000	380	8.8	25.5	0.0116	0L	385	140	159	6		
CM0H-1560D5R5-	5.5	1500/6000	1500/6000	380	12.2	35	0.0162	0H	445	200	219	6		
CM1S-1560D2R2-	2.2	1500/6000	1500/6000	380	4.8	14	0.0071	1S	334	65	-	-		
CM1M-1560D004-	4	1500/6000	1500/6000	380	8.2	25.5	0.0101	1M	369	100	-	-		
CM2S-1560D004-	4	1500/6000	1500/6000	380	8.2	25.5	0.0128	2S	375	109	-	-		
CM2M-1560D5R5-	5.5	1500/6000	1500/6000	380	11.2	35	0.0169	2M	405	139	-	-		
CM2L-1560D7R5-	7.5	1500/6000	1500/6000	380	15.3	48	0.0236	2L	455	189	-	-		
CM2H-1560D011-	11	1500/6000	1500/6000	380	22.2	70	0.0303	2H	505	239	-	-		
CM4S-1560D011-	11	1500/6000	1500/6000	380	21	70	0.0615	4S	482	133	-	-		
CM4M-1560D015-	15	1500/6000	1500/6000	380	28.4	96	0.0791	4M	510	173	-	-		

CM0S,0M,0L,0H series specification and dimensions

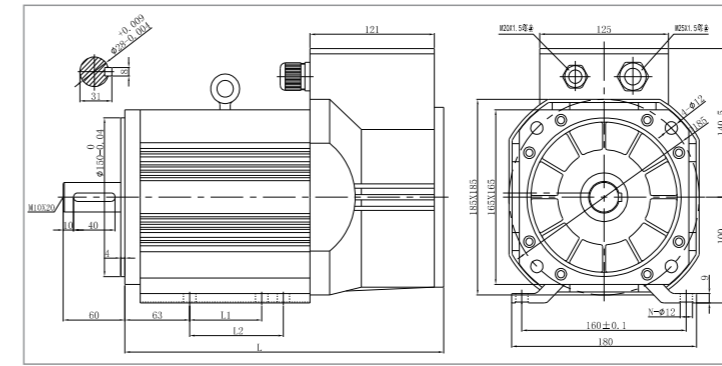

CM1S,1M series specification and dimensions

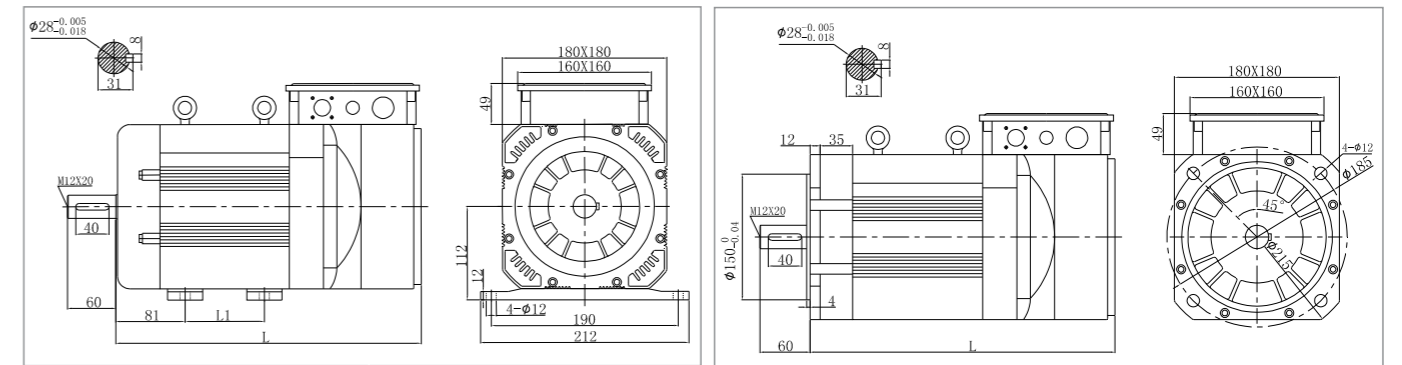

CM2S,2M,2L,2H series specification and dimensions

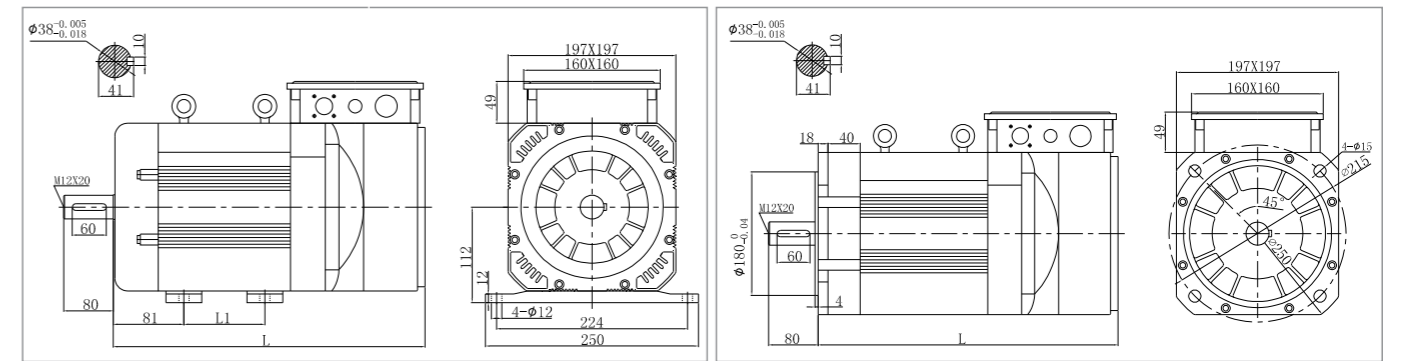

CM4S,4M series specification and dimensions

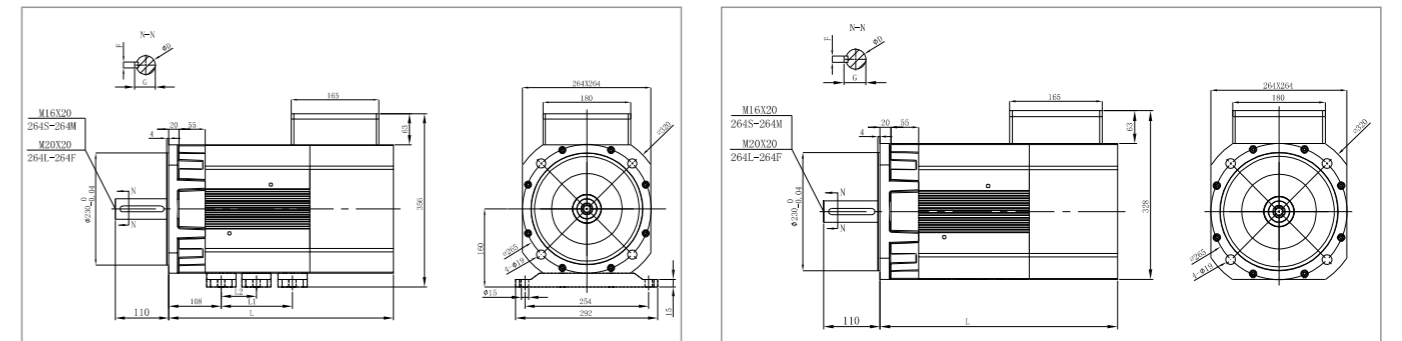

Standard diagram

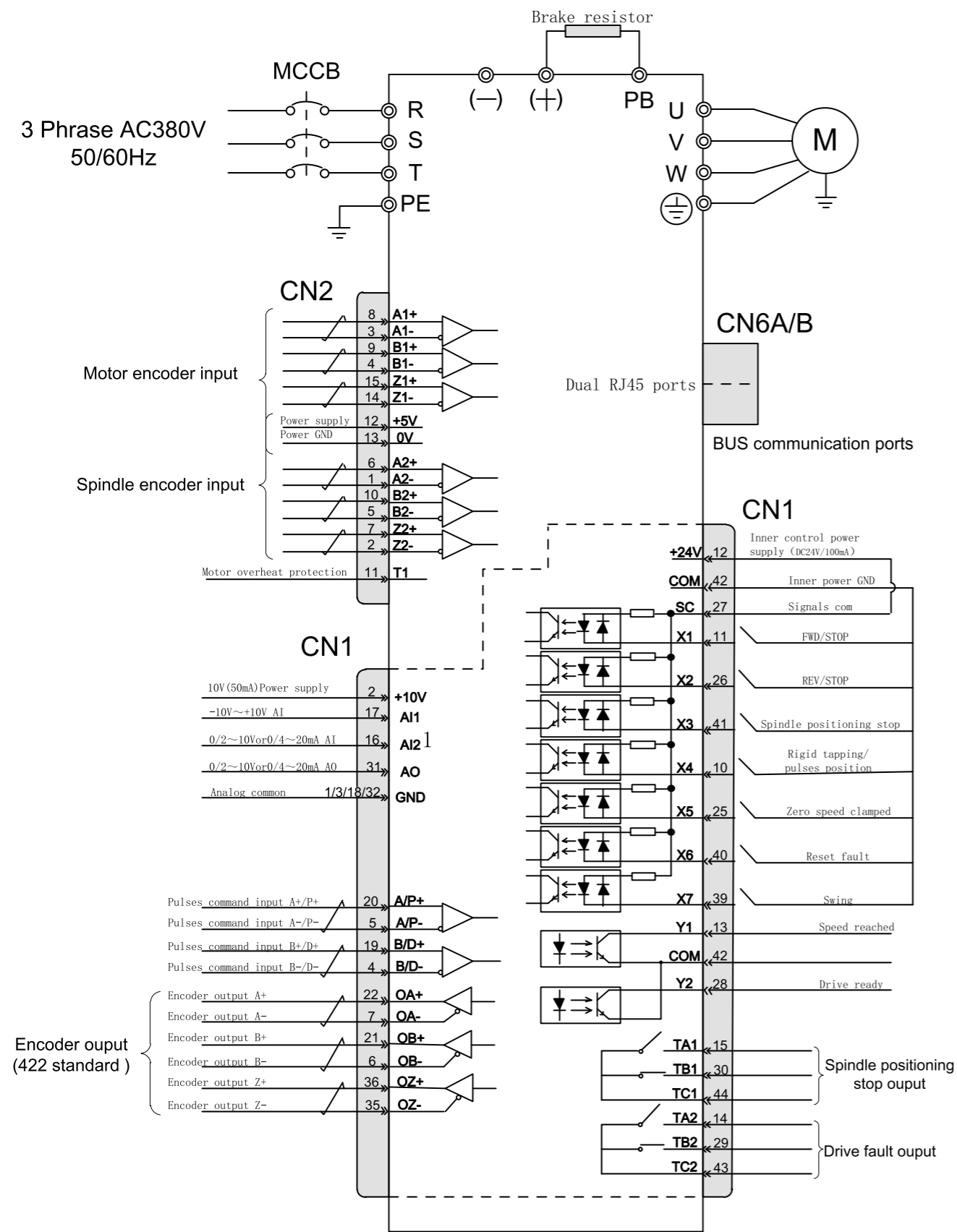

Special drive AC300-C for spindle industry

Simple shape, strong interior



Available open/close loop on AM/PM motor



Vector platform support 600Hz output



Accurate torque excitation decoupling ,excellent dynamic response



Book narrow structure design , optimize installation space



New cooling duct design ,DC fans heat dissipation ,high IP,safe and reliable



Package parameters for spindle machine ,brief the parameters setting



Reduce motor noise with random carrier



Strong response on load

Special drive AC300-Y for punch machine industry

Stable ,reliable ,safe



Book narrow structure design , optimize installation space



European-style terminals for easy wiring



Accurate torque excitation decoupling ,excellent dynamic response



Full motor auto tuning in dynamic /static state



Overcurrent ,overvoltage suppression function



Various expansion module , support customization requirements



Fast and stable speed tracking ,even 1Hz speed



Random carrier to reduce motor noise

Model explanation

AC300-T3-037 G/45 P-B (L) - *

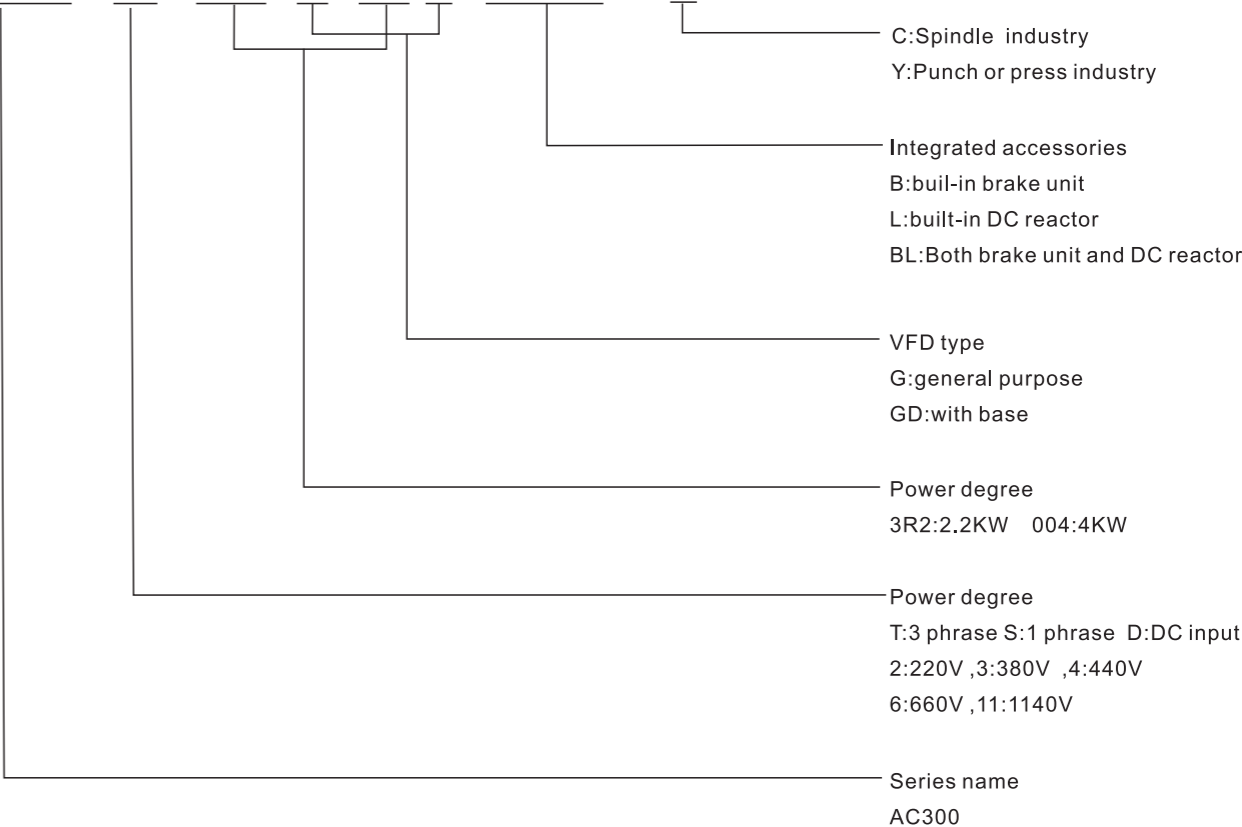

VFD rated output current

Voltage	220V	380V	Voltage	220V	380V
Power	Rated output AMP (A)		Power	Rated output AMP (A)	
0.75	4	3	110	380	210
1.5	7	4	132	420	250
2.2	10	6	160	550	310
4	16	10	185	600	340
5.5	20	13	200	660	380
7.5	30	17	220	720	415
11	42	25	250		470
15	55	32	280		510
18.5	70	38	315		600
22	80	45	355		670
30	110	60	400		750
37	130	75	450		810
45	160	90	500		860
55	200	110	560		990
75	260	150	630		1100
90	320	180	700		1260

Dimensions

Plastic cover type

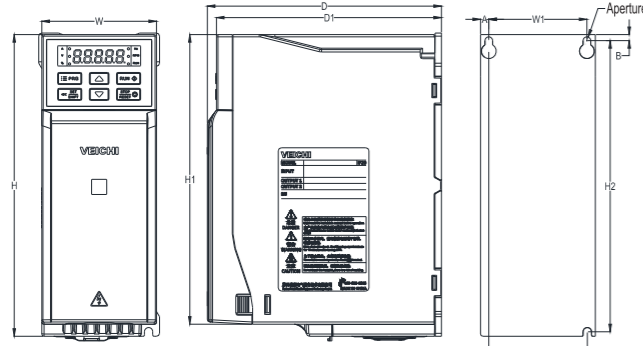

Model	Overall dimensions (mm)					Installation dimensions (mm)					Aperture
	W	H	H1	D	D1	W1	W2	H2	A	B	
AC300-S2-R75G-B-C	76	200	192	155	149	65	65	193	5.5	4	3-M4
AC300-S2-1R5G-B-C											
AC300-S2-2R2G-B-C	100	242	231	155	149	84	86.5	231.5	8	5.5	3-M4
AC300-S2-004G-B-C											
AC300-T3-R75G/1R5P-B-C	76	200	192	155	149	65	65	193	5.5	4	3-M4
AC300-T3-1R5G/2R2P-B-C											
AC300-T3-2R2G-B-C											
AC300-T3-004G/5R5P-B-*	100	242	231	155	149	84	86.5	231.5	8	5.5	3-M4
AC300-T3-5R5G/7R5P-B-*											
AC300-T3-7R5G/011P-B-*	116	320	307.5	175	169	98	100	307.5	9	6	3-M5
AC300-T3-011G/015P-B-*											

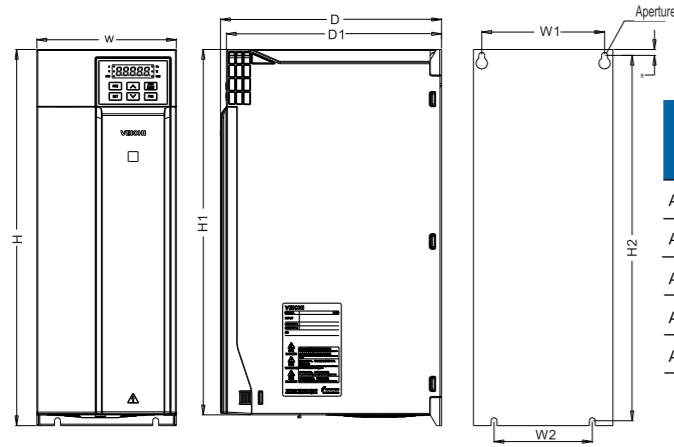

Model	Overall dimensions (mm)					Installation dimensions (mm)				Aperture	
	W	H	H1	D	D1	W1	W2	H2	B		
AC300-T3-015G/018P-B-*											
AC300-T3-018G/022P-B-*	142	383	372	225	219	125	100	372	6		4-M5
AC300-T3-022G/030P-B-*											
AC300-T3-030G/037P-*	172	430	/	225	219	150	150	416.5	7.5		4-M5
AC300-T3-037G/045P-*											

Iron cover type

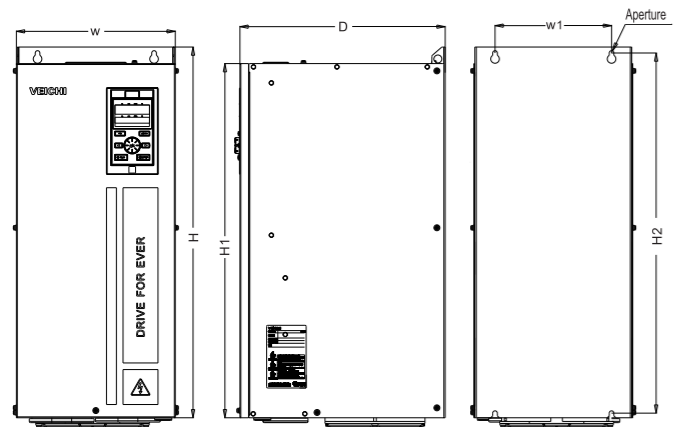

Model	Overall dimensions (mm)				Installation dimensions (mm)		Aperture
	W	H	H1	D	W1	H2	
AC300-T3-045G/055P-*							
AC300-T3-055G/075P-*	240	560	535	310	176	544	4-M6
AC300-T3-075G/090P-*							

SD700 Series high performance servo system

Perfect combination of extreme and concision



Speed loop bandwidth response up to 3KHz



24Bit absolute encoder , communication speed up to 4Mpps



Bandwidth ,PID loops gain parameters auto tuning



Powerful PC debugging software , multi channels to monitoring ,easy to use



Auto inertia identification ,loops gain and friction compensation parameters setting



Support multi segment vibration suppression ,inhibit resonance effectively



Robust control ,stable operation within 30 times inertia



New structure design ,compact , space-saving

Model explanation

SD 700 - 3R3 A - P A *

SD: servo product code

700: rotary servo motor series
710: linear servo motor series

Rated Current

(A) 220VAC				(D) 400VAC			
1R1	1.1A	7R6	7.6A	2R5	2.5A	110	11A
1R8	1.8A	9R5	9.5A	3R8	3.8A	170	17A
3R3	3.3A	120	12A	6R0	6.0A	240	24A
5R5	5.5A	160	16A	8R4	8.4A	300	30A

Rated voltage

A : 220VAC
D : 400VAC

Product management number
Standard product defaults

Encoder type
A: absolute type
B: incremental type
T: resolver type

Drive type
P: pulse type
S: standard type
C: CanOpen bus type
E: EtherCat bus type
M: MECHATROLINK-II bus type
L: MECHATROLINK-III bus type

Code	Model	Pulse Input	16-bit analog	full closed loop	RS485	CANopen	EtherCAT	MECHATRO LINK II	MECHATRO LINK III
P	Pulse type	√	×	√	√	×	×	×	×
S	Standard type	√	√	√	√	√	×	×	×
C	CANopen type	√	×	√	√	√	×	×	×
E	EtherCAT type	×	×	√	√	×	√	×	×
M	MECHATROLINKII type	×	×	√	√	×	×	√	×
L	MECHATROLINKIII type	×	×	√	√	×	×	×	√

Servo motor model introduction

VM7 - L 06 A - 1R0 15 - D 1 □

Product series
VM5
VM7

Inertia level
L : Low inertia
M : Middle inertia
H : High inertia

Install flange
04: 40mm 11: 110mm
06: 60mm 13: 130mm
08: 80mm 18: 180mm
10: 100mm

Rated voltage
A: 220VAC
D: 400 VAC

Rated power

Mark	Power(W)	Mark	Power(W)	Mark	Power(W)	Mark	Power(W)
R05	50	R75	750	1R5	1500	2R9	2900
R10	100	R85	850	1R8	1800	3R8	3800
R20	200	1R0	1000	2R0	2000	4R4	4400
R40	400	1R2	1200	2R3	2300	5R5	5500
R60	600	1R3	1300	2R6	2600	7R5	7500

Inner manager number

Mark	Axis		Oilseal		Brake	
	Optical axis	Key axis	Yes	No	Yes	No
1	●	●				●
2	●	●			●	

Encoder type
D: 23 bit integrated multiloop absolute encoder
E: 24 bit integrated multiloop absolute encoder
F: 24 bit split-type single loop absolute encoder
G: 20 bit integrated multiloop absolute encoder
K: 19 bit split-type single loop absolute encoder

Rated speed (RPM)
15: 1500
20: 2000
25: 2500
30: 3000

Model motor VM-□-	Mootr model										
	L08A-R7530-D□	L08A-1R030-D□	M13A-1R020-D□	M13A-1R520-D□	M13A-2R020-D□	M13A-2R315-D□L	M13A-2R625-D□L	M18D-2R915-D□	M18D-4R415-D□	M18D-5R515-D□	M18D-7R515-D□
Rated voltage (V)	220	220	220	220	220	220	220	400	400	400	400
Rated power (W)	750	1000	1000	1500	2000	2300	2600	2900	4400	5500	7500
Rated RPM (RPM)	3000	3000	2000	2000	2000	1500	2500	1500	1500	1500	1500
Max RPM (RPM)	6000	5000	3000	3000	3000	2000	3000	2000	1800	1800	2000
Rated torque (N.m)	2.4	3.18	4.77	7.16	9.5	14.6	10	18.5	28.1	35	47.7
Max torque (N.m)	7.2	9.54	14.3	21.48	28.5	43.8	30	46.3	70.3	105	119.3
Rated current (A)	4.8	5.3	4.9	7.1	9.1	9.4	9.4	7.1	9.9	12.7	19.1
Max current (A)	14.4	15.9	14.7	21.3	27.3	28.2	28.2	17.8	24.8	38.1	47.8
Torque factor (N.m/A)	0.54	0.6	1.03	1.06	1.06	1.61	1.11	2.75	3.01	3.03	2.67
Rotary inertia (Brake) (kg.cm ²)	1.30 (1.50)	1.66 (1.89)	13.1 (15.2)	18.7 (21.5)	24.3 (27.3)	37.2 (40.2)	24.3 (27.2)	47.9 (53.7)	72.3 (78.1)	110.1 (115.8)	156.9 (162.7)

Servo motor install dimensions

80 flange

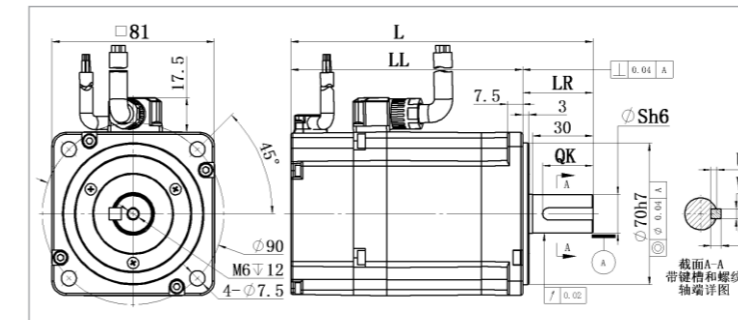

Motor mode VM7-	L	LL	LR	S	U	W	T	QK
VM7-L08A-R7530-D1L	153	118	35	19	3.5	6	6	25
VM7-L08A-R7530-D2L	195	160	35	19	3.5	6	6	25
VM7-L08A-R7530-D1	153	118	35	19	3.5	6	6	25
VM7-L08A-R7530-D2	195	160	35	19	3.5	6	6	25
VM7-L08A-1R030-D1	177	142	35	19	3.5	6	6	25
VM7-L08A-1R030-D2	217	182	35	19	3.5	6	6	25

130 flange

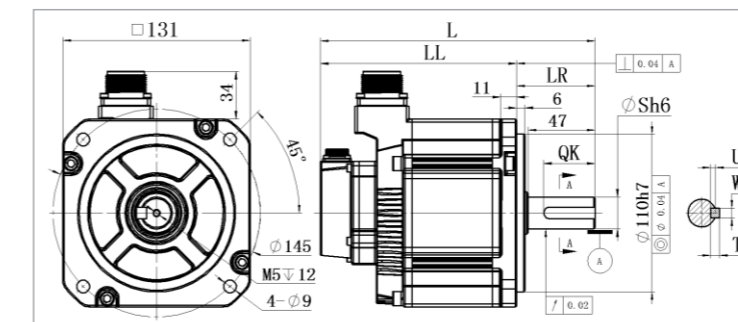

Motor mode VM7-	L	LL	LR	S	U	W	T	QK
VM7-M13□-1R020-D1	192	137	55	22	4	8	7	36
VM7-M13□-1R020-D2	229	174	55	22	4	8	7	36
VM7-M13□-1R520-D1	207	152	55	22	4	8	7	36
VM7-M13□-1R520-D2	244	189	55	22	4	8	7	36
VM7-M13□-2R020-D1	222	167	55	22	4	8	7	36
VM7-M13□-2R020-D2	259	204	55	22	4	8	7	36
VM7-M13□-2R315-D1L	257	202	55	22	4	8	7	36
VM7-M13□-2R315-D2L	299	244	55	22	4	8	7	36
VM7-M13□-2R625-D1L	222	167	55	22	4	8	7	36
VM7-M13□-2R625-D2L	259	204	55	22	4	8	7	36

180 flange

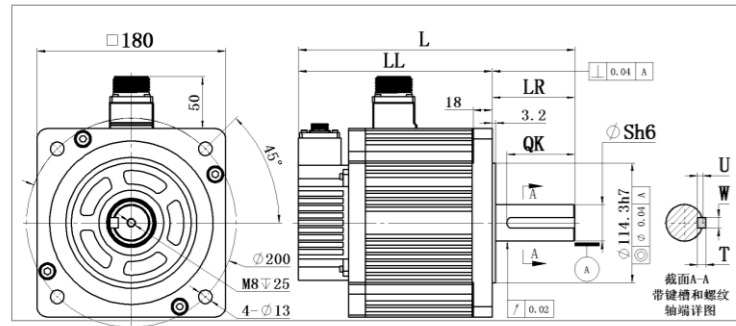

Motor mode VM7-	L	LL	LR	S	U	W	T	QK
VM5-M18D-2R915-D1	264	185	79	35	5	10	8	65
VM5-M18D-2R915-D2	325	246	79	35	5	10	8	65
VM5-M18D-4R415-D1	288	209	79	35	5	10	8	65
VM5-M18D-4R415-D2	371	292	79	35	5	10	8	65
VM5-M18D-5R515-D1	325	246	79	35	5	10	8	65
VM5-M18D-5R515-D2	371	292	79	35	5	10	8	65
VM5-M18D-7R515-D1	371	292	79	35	5	10	8	65
VM5-M18D-7R515-D2	427	348	79	35	5	10	8	65

SD700 Servo drive wire introduction

Power cable naming rules

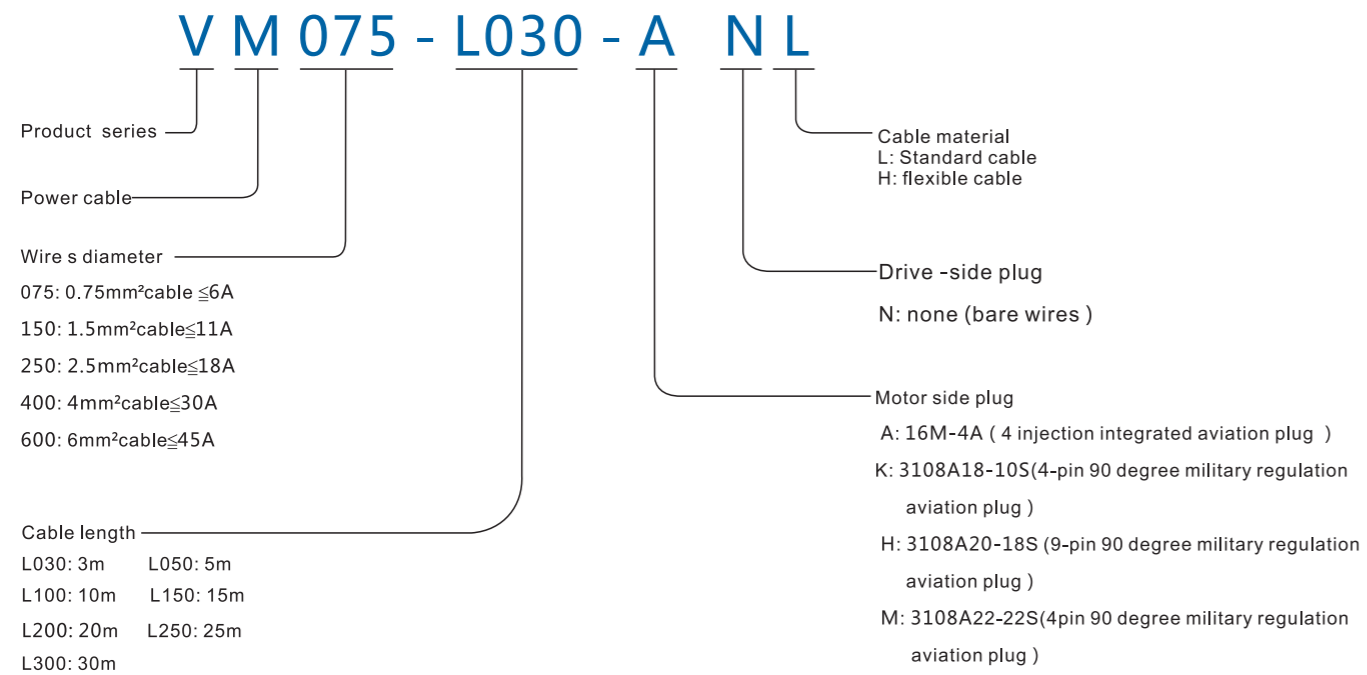

Motor power cable

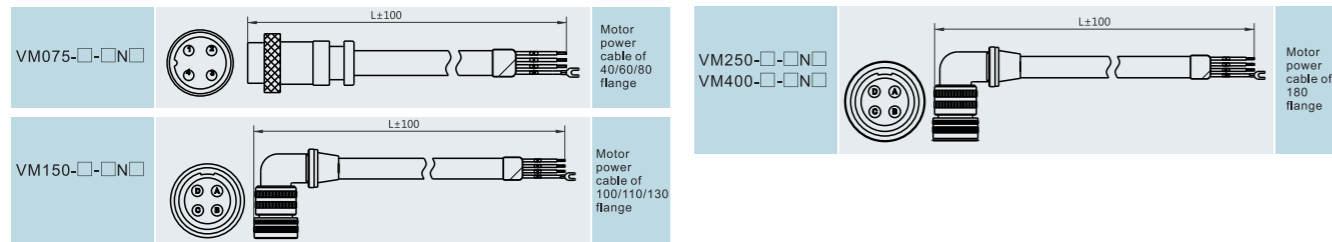

Encoder cable naming rules

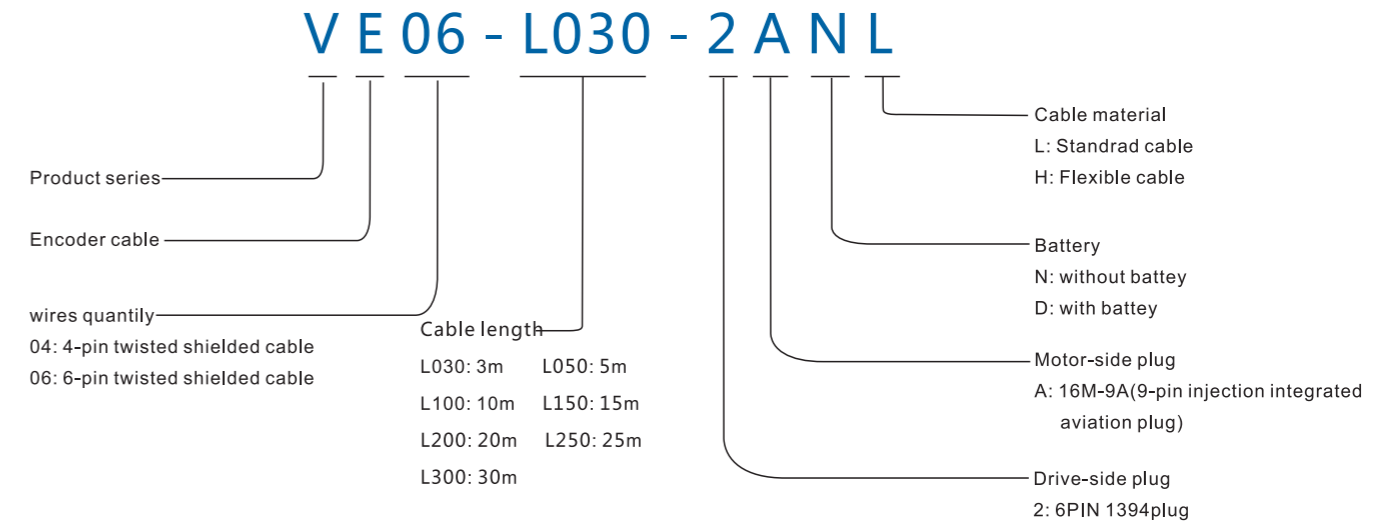

Encoder cable



Servo model selection

Voltage (V)	Motor			Drive model +2	Motor cable +3	Encoder cable +3
	Power (W)	Model	Rated AMP (A)			
220	750	VM7-L08A-R7530-D□	4.8	SD700-5R5A-□□	VM075-L□□□-AN□	VE04-L□□□-2AN□ With/without battery box : VE06-L□□□-2AD□
	1000	VM5-L08A-1R030-D□	5.3			
		VM7-M13A-1R020-D□	4.9			
	380	1500	VM7-M13A-1R520-D□	7.1	SD700-7R6A-□□	
2000		VM7-M13A-2R020-D□	9.1	SD700-9R5A-□□		
2300		VM7-M13A-2R315-D□L	9.4		SD700-8R4D-□□	
2600		VM7-M13A-2R625-D□L	9.4			
2900		VM5-M18D-2R915-D□	7.1	SD700-110D-□□		
4400		VM5-M18D-4R415-D□	9.9			
5500	VM5-M18D-5R515-D□	12.7	SD700-170D-□□			
7500	VM5-M18D-7R515-D□	19.1	SD700-240D-□□			

* 1□□ 1:with brake ,2:without brake.

* 2 : □□ PA :pulses type ,MA :Mechatrolink-□,EA:EtherCat,CA:CANopen.

* 3 : □□□ cable length ,030=3 m,050=5 m,100=10 m,150=15 m, for other length please contact the manufacturer .L =general cable , H=flexible cable .

* 4 : 40/60/80/180 flange motor with brake configure brake cable interface ,130 flange motor with brake integrate this interface in special motor power cable (-KN/HN).

Series configuration drawing

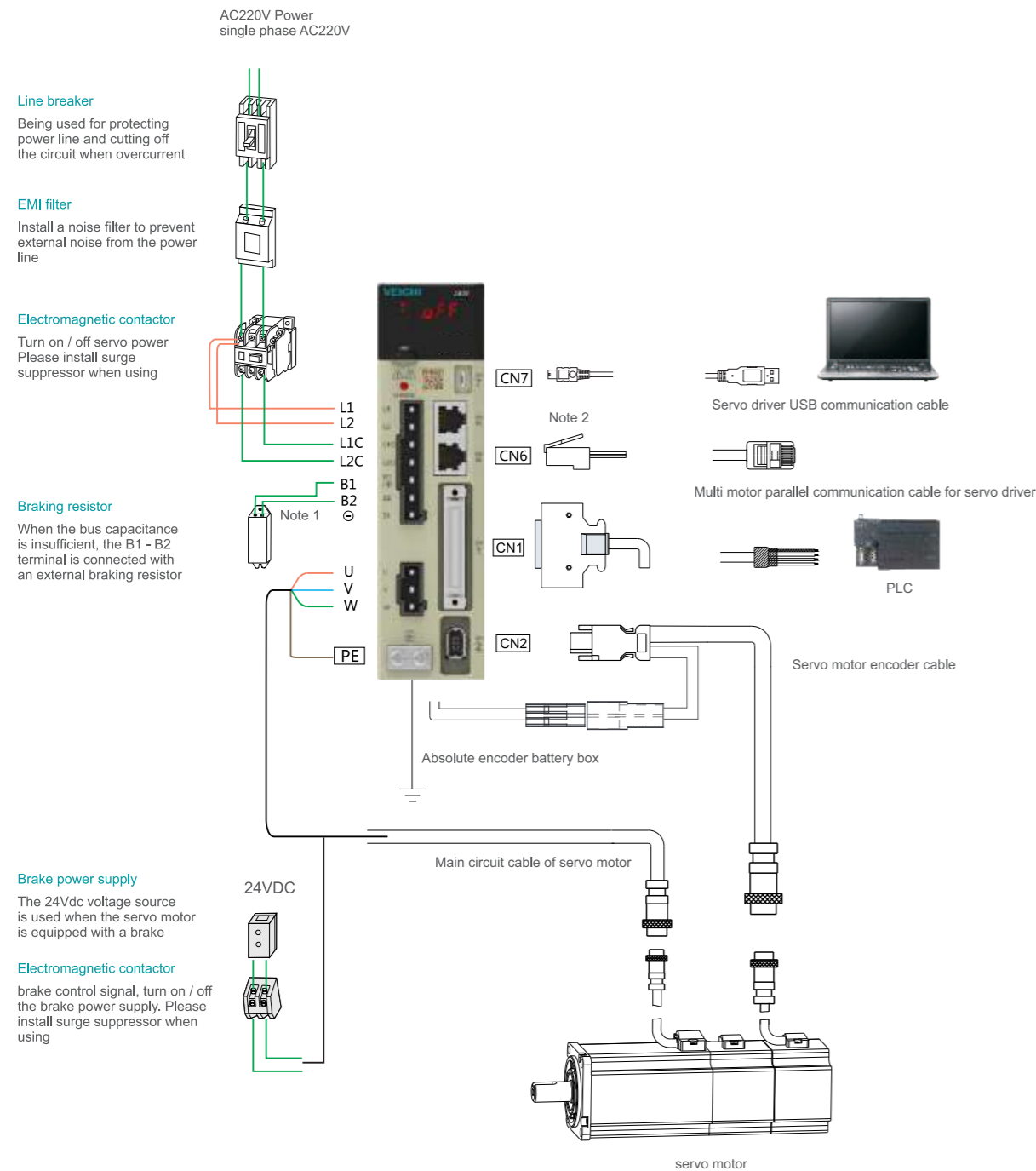

Standard wiring diagram - position mode

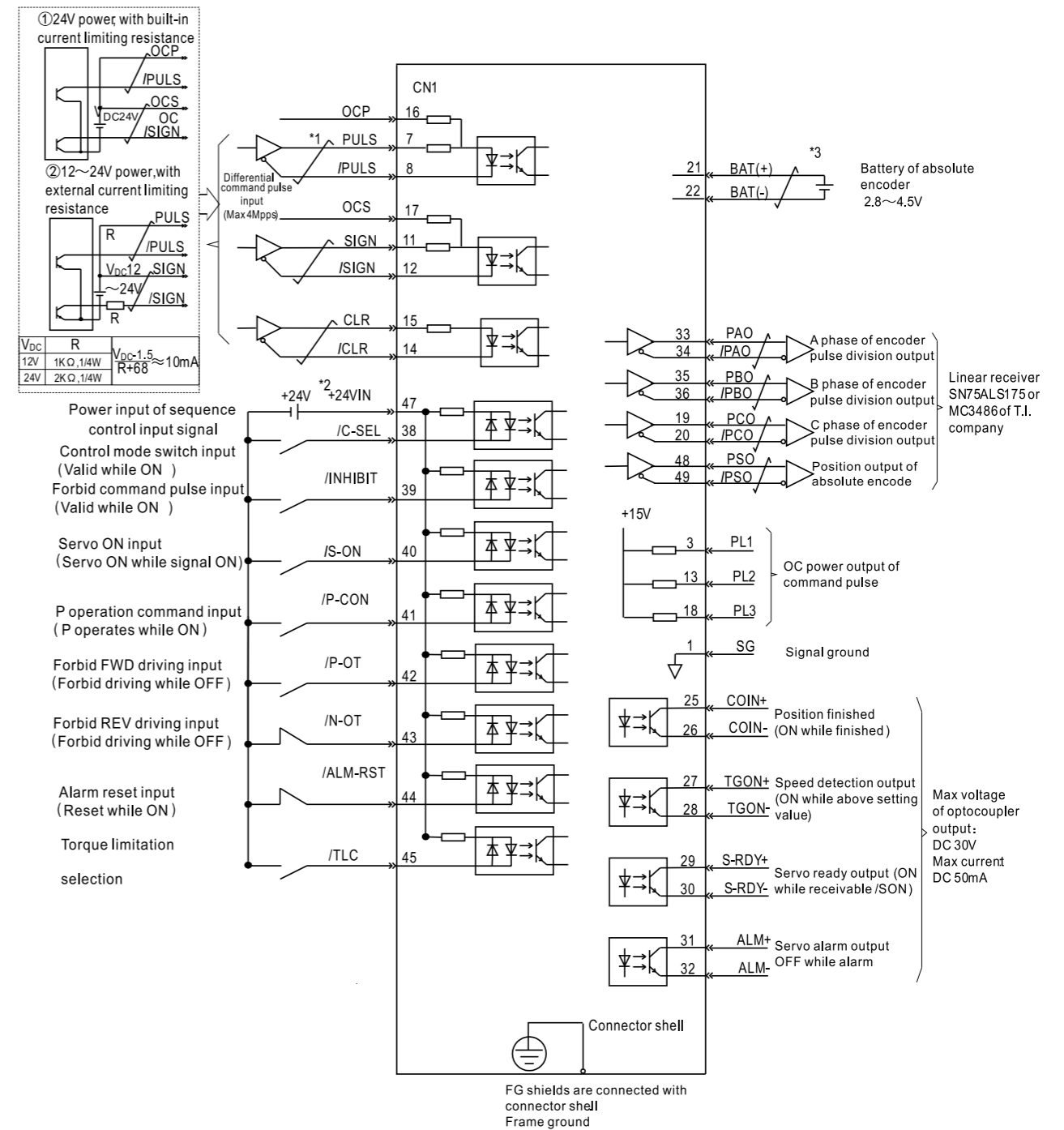

Application

Slanting lathe solution

Solution advantage

- 1.Feed axis, power head servo supports a variety of bus protocols, (Mechatrolink-□, Mechatrolink-□, EtherCat) power head dedicated servo motor large output torque, the maximum speed up to 6000 rpm, and the milling plane is smoother;
- 2.Standard configured dual PG interface ,receive feedback from servo motor and spindle motor at same time ,higher control precision ;
- 3.Servo integrated AM/PM motor control mode ,open /close loop mode ,large torque in low frequency ,excellent ACC/DEC response ability ;
- 4.Adapt to all kinds of systems, smooth processing cutting speed, delicate processing of workpiece lines, high gloss.

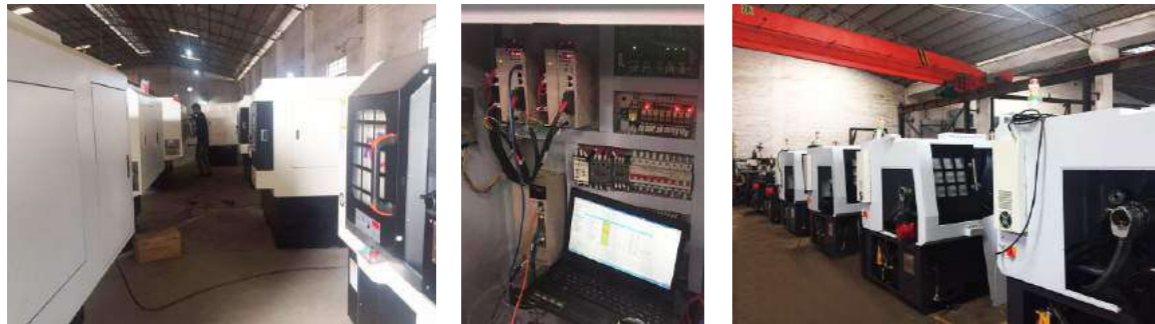
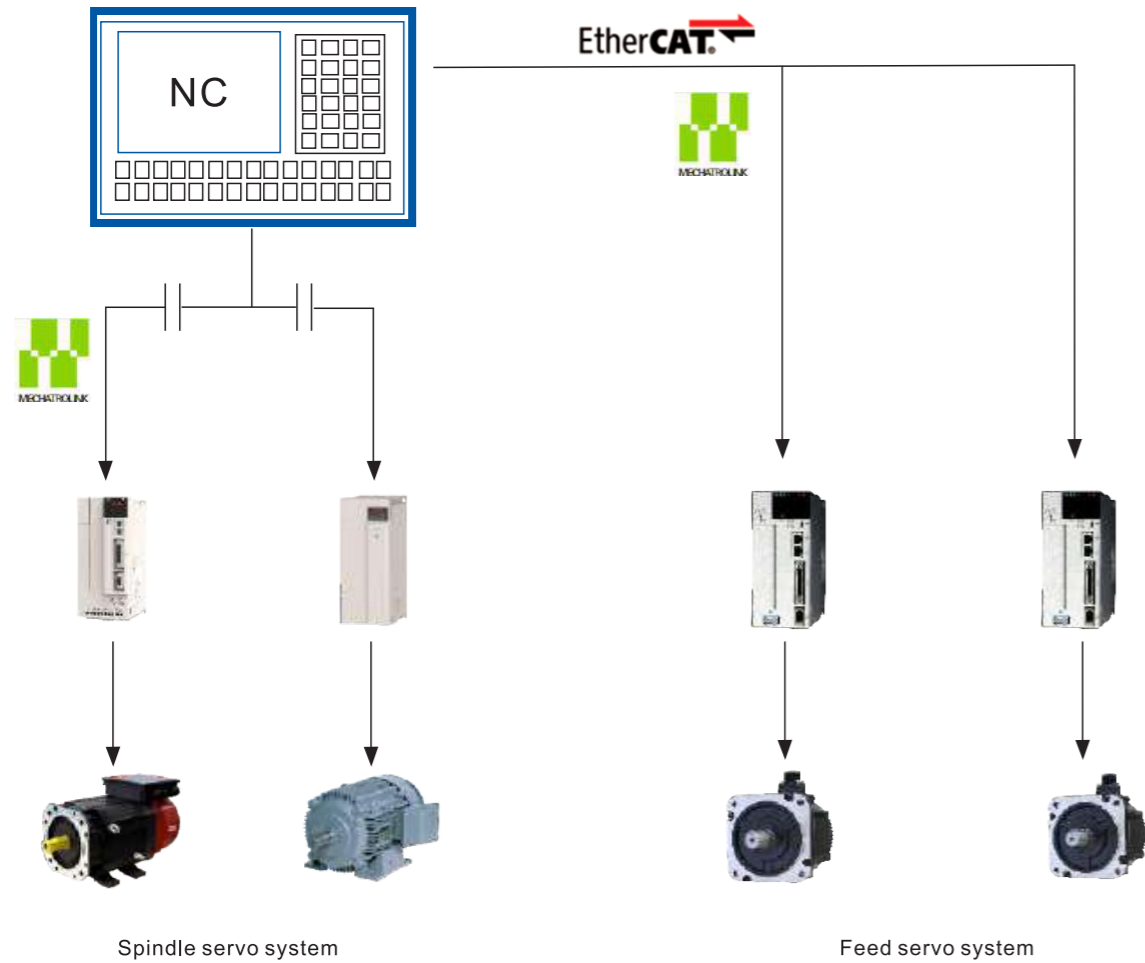

CNC lathe & milling machine combination machine solution

Solution advantage

- 1.Feed axis, power head servo supports a variety of bus protocols, (Mechatrolink-□, Mechatrolink-□, EtherCat) power head dedicated servo motor large output torque ,the maximum speed up to 6000 rpm, and the milling plane is smoother;
- 2.Spindle servo positioning stop in full close loop ,within ±1pulse ;
- 3.The dedicated servo of the tool magazine can drive up to 32 knives, with high positioning accuracy and repeat positioning accuracy, and quick tool change;
- 4.Adapt to all kinds of systems, smooth processing cutting speed, delicate processing of workpiece lines, high gloss.

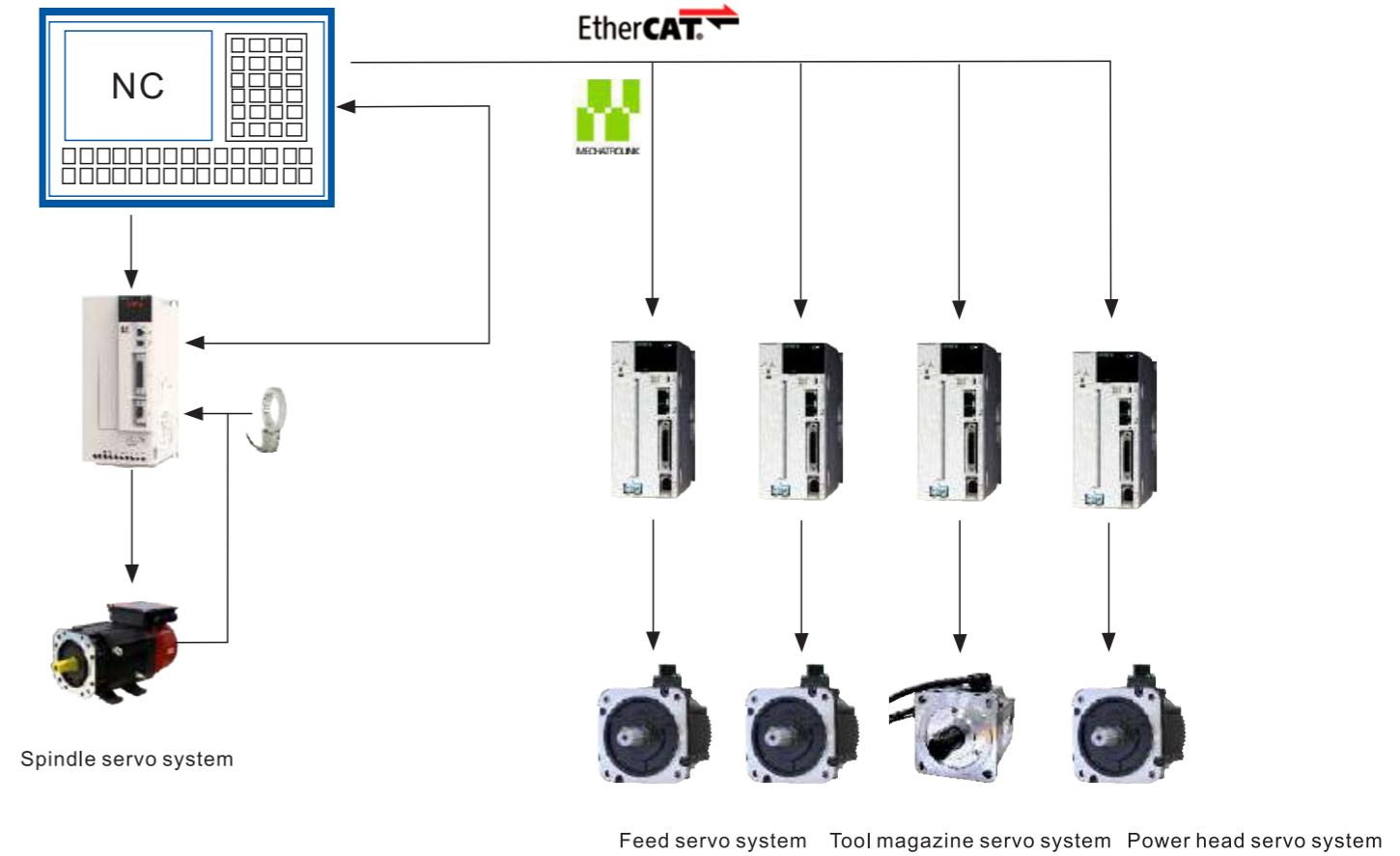

Other application

VEICHI Electric industrial product are comprehensive applied on engraving and milling machine, tapping center , wooden engraving machine , gantry milling machines, press equipment, and work closely together with system manufacturers to provide optimal solution to customers;



Company profile



Founded in 2005, VEICHI Electric is a national high-tech and a “dual-soft ” enterprise engaged in the research, development, production and sales of industrial automation products. It has established two research and production bases with independent intellectual rights in Shenzhen and Suzhou. The ever-increasing ability to innovate, highlighting flexible customization capabilities, and increasingly improved delivery capabilities have earned the trust and cooperation of customers around the world.

The company's products cover the general VFD, servo and motion control system, integrated special drive and Internet of Things, etc., and provide advanced industry integrated solution and design for printing and packaging, pumps, machine tools and compressors, hydraulic servo, lifting, textile and other industries. Product development and design, comprehensive product development testing and automated information production, to provide customers with the most optimized industrial automation system solutions.

The core talents and backbone talents in the product R&D field of the industry meet the needs of talents in future R&D planning. The company has independent intellectual property rights and core technologies, and at least 10% of annual sales revenue will be invested in product development.

In the future, VEICHI Electric will continue to drive the endless brand strength and create a better tomorrow with you.